

FUJIFILM
Value from Innovation

DIGITAL MINILAB
Frontier

LP 5700R
LP 5500R



Exceptional Speed and Productivity Provide
Further Strength to Your Print Business



Advanced Frontier hardware and supporting Fujifilm products are the keys to "Prints in Minutes" service

Image Intelligence™

Original image

Optimized image after image processing

Frontier LP5700R

Approx. **2,040** prints/hr

Frontier LP5500R

Approx. **1,210** prints/hr

4R size

2'28"

(Dry-to-dry: 1'22")

Frontier LP5700R

2'55"

(Dry-to-dry: 1'22")

Frontier LP5500R

Increased processing capacity allows you to handle more business and offer faster services to your customers.

With faster across-the-board processing (including dry-to-dry time of only 1'22"), now drop-off, processing, and pick-up can be accomplished in a single trip.

The wider range of sizes includes prints up to 12 x 18 inches. Even at these large dimensions, the prints have beautiful image quality and crisp, clear resolution.

More compact dimensions and three-sided maintenance give you greater flexibility and space efficiency in the physical layout of your store.

Digital Minilab Frontier LP5700R/LP5500R Main Specifications

Processing capacity	Print sizes	Paper Widths	LP5700R	LP5500R
	3 R	127 mm (5")	Approx. 2,210 prints/hr	Approx. 1,350 prints/hr
	4 R	152 mm (6")	Approx. 2,040 prints/hr	Approx. 1,210 prints/hr
	12 R	305 mm (12")	Approx. 300 prints/hr	Approx. 300 prints/hr
Print sizes	82.5 mm (3.2") x 117 mm (4.6") ~ 305 (12") x 457 mm (18")			
Processing chemicals	Chemical system CP-49E			
Footprint space	Approx. 1.2 m ² (included optional unit)			

Laser Printer/Paper Processor LP5700R and LP5500R

Type	Floor-type, normal light operation (laser printer, processor, cutter and sorter in one unit)
Exposure system	Scanning exposure system using RGB lasers
Paper magazines	Two switchable paper magazines (standard accessory)
Paper	FUJICOLOR paper (silver-halide)
Paper widths	89 mm (3.5"), 102 mm (4"), 117 mm (4.6"), 127 mm (5"), 152 mm (6"), 203 mm (8"), 210 mm (8.3"), 254 mm (10"), 279 mm (11"), 297 mm (11.7"), 305 mm (12")
Back printing	Two 40-character lines in backside print of information
Printer sorter	LP5700R: SU1400AY, sorting capacity: 14 orders of C/H/P-mixed format prints LP5500R: SU700AY, sorting capacity: 7 orders of C/H/P-mixed format prints
Printer condition setup	Semi-automatic calibration by AD300 calibrator
Processing time	Dry-to-dry: 1 min. 22 sec.
Power requirements	AC200-240V (50/60Hz) Single-phase 24A, Three-phase four-wire 17A, Approx. 4.8KVA
Dimensions	LP5700R (with 14-order sorter): 1,515 (W) x 820 (D) x 1,390 (H) mm LP5500R (with 7-order sorter): 1,515 (W) x 820 (D) x 1,390 (H) mm
Weights	LP5700R (with 14-order sorter): Approx. 470 kg (520 kg during actual operation) LP5500R (with 7-order sorter): Approx. 460 kg (510 kg during actual operation)

Performance varies depending on processing capabilities of the Imaging Controller.
Specifications are subject to change without notice.
All brand names or trademarks are property of their respective owners.

Dimensions

Unit: mm

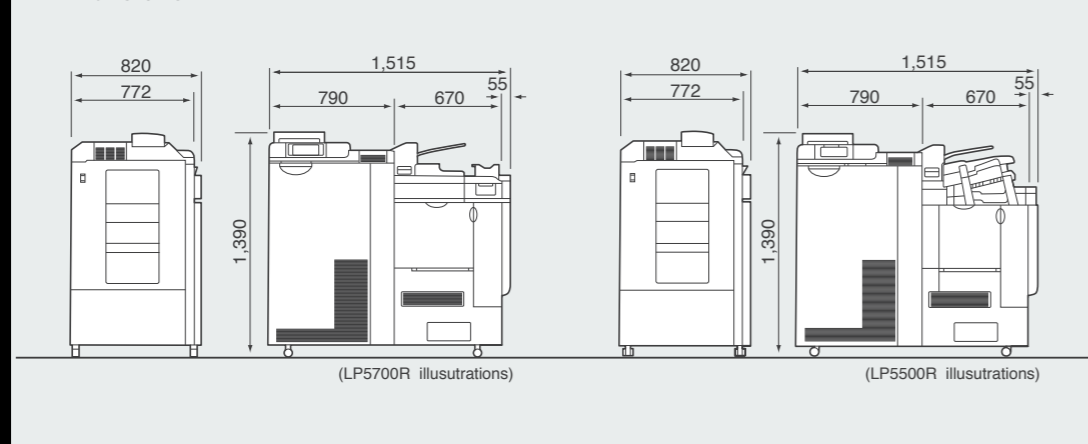

Exceptional Speed and Productivity Provide
Further Strength to Your Print Business